

31. Firewall

A fire proof barrier is to be fitted to the front of the landing gear mounting frame between the two footwells.

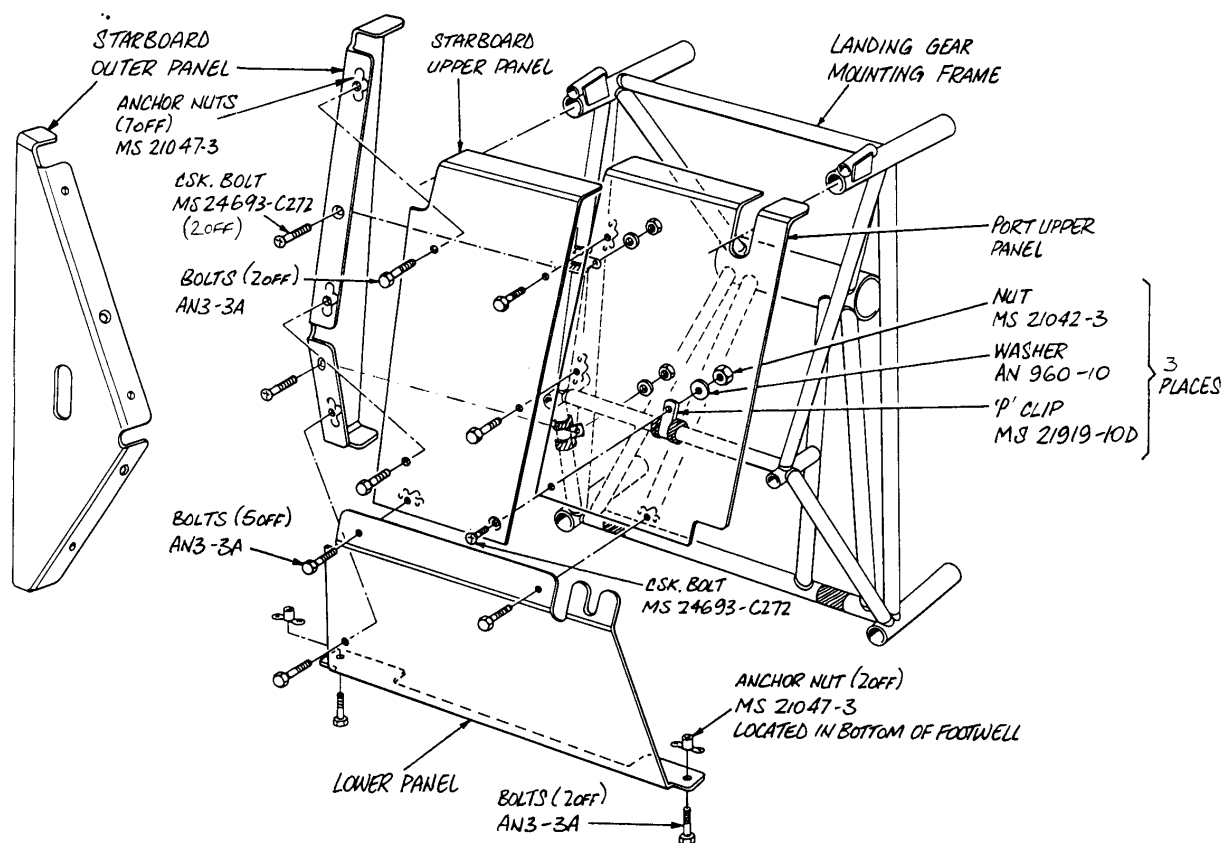

Fig 1. Exploded view of firewall assembly (monowheel frame shown - trigear is similar).



To enable its installation with the engine mounting in place the firewall is made up of four stainless steel panels ; two upper panels, one lower panel, and one side panel. See figure 1.

Two of the upper panels are narrow enough to pass through the gap between the engine mounting's lower shock mountings for installation which are then fastened together using two bolts. These two panels are then secured to the landing gear mounting frame via a P-clip. The side panel, which blanks off the angled starboard side of the landing gear mounting frame, is necessary to allow clearance for the starboard rudder pedal crank CS21 when it pivots aft. P-clips around the mounting frame members are used with which to attach this panel.

The lower panel is bolted to the upper panels and fastened to the port side of the footwell and the side panel. Full size templates are to be found in Annex F which may require slight adjustment for your particular fit.

Step 1

Make templates from cardboard with which to carry out fitting trials and adjustments then, using these, mark out and reproduce them using the thin stainless steel sheet provided. Medium duty scissors are sufficient with which to cut the steel. Remove all sharp edges and corners with a file and use protective gloves when handling the steel until you have done this.

Using a sharp 4.8 mm drill, drill holes for the AN3-3A bolts and rivet MS21047-3 anchor nuts to the back of the panels in the seven positions required using TAPK 33 BS rivets.

The lower central hole is used to fasten the two upper panels to the landing gear mounting frame via a P-clip using a countersink screw so the lower panel can lap over them..

Step 2

Spring a P-clip around each of the two angled struts which meet at the starboard lower engine mounting tube so that their lugs are pointing inboard. Drill and bolt the side panel to these P-clips using MS24693-C272 countersunk bolts, MS21042-3 nuts and AN960-10 washers. Seal the edges of the panel to the footwell using high temperature silicone R.T.V.

Step 3

Spring the P-clip around the cross-member of the landing gear mounting frame, between the two lower engine mounting tubes, with the lug upwards and locate it mid way along the tube.

Slide the two upper firewall panels into place and bolt them together with AN3-3A bolts, also fastening them to the P-clip using the MS24693-C272 countersunk bolt, AN960-10 washer, and an MS21042-3 nut.

Now position the lower panel and bolt it to the upper plates with AN3-3A bolts.



Step 4

Push the lower panel in position relative to the landing gear mounting frame and drill through the first skin only in the port side of the footwell with a 4.8 mm drill using the lug as a guide. Remove the lower firewall panel and open the holes in the footwell to 8 mm (5/16") to allow the body of an anchor nut through. Rivet an MS21047-3 anchor nut onto the footwell sidewall with the back face of the nut outermost so it is almost flush with the surface, using TAPK36BS rivets.

Reinstall the lower firewall panel and bolt it also to the footwell side.

Using Silicon R.T.V. (High Temperature), seal around all the edges and around the landing gear mounting frame to prevent gasses passing into the wheel well.

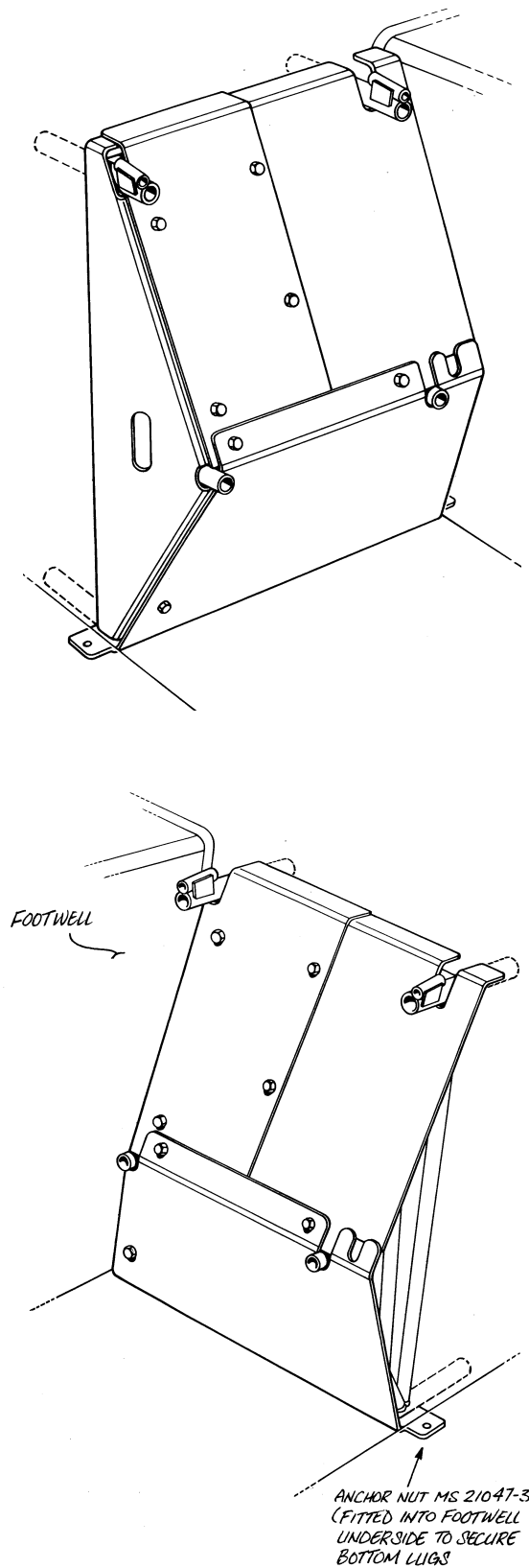

Fig 2. Firewall panels installed positions.