

Aircraft Cooling 101 for Tractor Engine Installation
Specifically for the
Europa Owners Forum
at
Rough River Fly
Presented by Bud Yerly
Custom Flight Creations, Inc.

This briefing is a compilation of information specifically for the Europa Owners and the cooling issues which affect those with the 914 and 912S engines. It is a series of fixes and or experiments I have found to rectify cooling issues in our aircraft. Part 1 is, understanding basic propulsion issues as related to cooling. Part 2, is the Rotax cooling requirements / radiator sizing and a description of the Europa stock aircraft cowl cooling / ducting. Part 3 is a practical analysis of the XS cowl problems of cooling the opposed 4 cylinder Rotax engine using the stock cowl, and some acceptable modifications for successful cooling with this cowl. Part 4 is other cooling techniques for the existing cowl which may improve cooling efficiency. Part 5 is some examples of future cowls for the Europa XS. The Reference section contains many informative topics on radiators and cylinder cooling even applicable to the Jabiru engine powered Europa enthusiast.

Part 1.
Basic Propulsion Design Concerns

- I. Basic engine cooling requirements must be determined early in the design process:
The requirements of a cooling system (in BTUs) must meet the following for successful light aircraft engine operations year round:
 - A. Ground ops Taxi/idle
 - B. Takeoff/Run-up
 - C. Climb at Continuous Power
 - D. Normal Cruise and Economical Cruise at Recommended Power Settings
 - E. Rapid Descents/Throttle Transients
 - F. Max Power / Max Speed

- II. Transmission of Power
 - A. The propeller power transmission or torque curves should be known and are assumed at 78%
 - B. Propeller air movement around the cowl inlets must be known to determine the inflow rates for all ground conditions. Flight conditions are assumed to be free air stream speeds.

- III. A/C Engine Cowl/Nose Shape.
 - A. Normally the aircraft nose shape is determined by the designer and has some concern about cooling inlets and exits, but normally is purely aerodynamics and sized to meet propeller spinner and a smooth engine enclosure.
 - B. Inlet shapes, areas and placement are made based on the ideal cruise conditions and average inlet and exit areas proposed by the engine manufacturer.

Example: The P-40B had a clean smooth pleasingly shaped inlet for the Allison engine. It performed well in normal takeoff and cruise for a standard day. Evidence from theater

operations proved the inlet must be enlarged to house the increased radiator size for desert operations at low altitude and higher than standard operating temperatures. The P-40E has a very large inlet packed with radiators and oil coolers to accomplish this. Not very pretty, but effective. Not very aerodynamic, but for ground attack, top speed and cruising efficiency were secondary.

IV. Cooling Techniques:

- A. Radiators: Radiator Areas and Flow Rates of the glycol and cooling air must be provided for proper sizing of the radiator and inlet. Augmenters, such as variable cowl inlets and exits and or thermostatic control of the cooling must be determined from engine test runs.
 - 1. Each operating envelope must be gauged from I above to insure the engine temperatures can be kept within limits.
 - 2. Operational procedures must be written to ensure proper pilot speed, power setting and configurations are maintained for the flight phases.
 - 3. Basic good operating principles such as run up into the wind, hold into the wind when possible, limit high RPM when on the ground are assumed.
- B. Engine accessories and their air cooling must be anticipated.
 - 1. Many water cooled engines still require some air cooling such as on the Rotax cylinders. These finned areas need air cooling commensurate with their BTU transfer requirements.
 - 2. Alternators and under cowl components such as regulators, ignition modules or gasolators must be cooled for proper operation and longevity.
 - 3. Fuel and oil lines must be protected when near exhaust or when trapped in hot air stagnation areas to provide a long service life and prevent vaporization issues.
- C. Engine compartment purge.
 - 1. Mufflers are necessary for happy neighbors but the heat of the exhaust system must be purged from the engine compartment and from overheating other lines or components especially during ground operations.
 - 2. Cowl materials (fiberglass) must be protected from excessive heat.
- D. Designs to meet all the above criteria are sent back to the designer from the propulsion engineers for incorporation into the nose cowl design. There the duct size and design is redrawn into the basic cowl design and exit ducts are redesigned to reintroduce exhausted air into the slipstream. Here provisions for aerodynamic gimmicks such as cowl flaps and inlet scoops are finalized.

V. Testing and validation.

The final configuration must be exhaustively tested and fine tuned for before production can take place and the prototype must be modified for production. It is easy to one off a component, but full production must include cost, time and materials. Kit manufacturers also must consider the capabilities of the average builder to install the fire wall forward components.

Part 2

914 Rotax Cooling Requirements (the worst case scenario)

- I. The Rotax 914 manufacturer supplied heat transfer and recommended cooling radiator sizes are provided as follows (Ref Rotax installation Manual 1996):
 - A. BTU transfer rates for takeoff power:
 1. Cylinder head cooling requirements and radiator sizing:
 - a. Radiator thermal transfer rate: 28 BTU/sec
 - b. Min Radiator sized of 78 square inches is required
 - c. Coolant flow rate 16 gallons per minute
 2. Cylinder ram air cooling requirements:
 - a. Cylinder air cooling of 5.7 BTU/s
 - b. Minimum air inlet of 16 square inches of inlet is required.
 - c. Rotax recommends an air duct or partition to force air past the finned cooling surfaces of the engine cylinders.
 3. Oil cooling requirements:
 - a. Oil cooler must dissipate 8.5 BTU/sec
 - b. Rotax recommended size is 25 square inches
 - c. Rotax recommends the oil cooler reside beneath the engine, but with the oil tank level set at approximately 400mm or less below the prop shaft level and the cooler below that.
 4. Fuel system components:
 - a. Fuel temperatures in excess of 100 F are not permissible, and cowl temps in the vicinity of fuel lines float chambers and such must be maintained below this temp.
 - b. Air box intake air (after turbo discharge) is limited to 162F
 5. Exhaust component contribution to cowl heat extraction (estimated by author):
 - a. Exhaust gas temperatures at max are nearly 1750 F. The muffler/Turbo in most operations is nearly 1000 F in places. The majority of the heat of these components is carried away out the exhaust pipe, but components will normally heat up to nearly 600 F due to heat transfer between the air and metal components. The estimated area of muffler and turbo components is 200 square inches.
 - b. Rate of heat transfer to prevent any exhaust heat build-up is estimated at 200 BTU/sec. This is a very large number. Exhaust components are designed to flow heat through the exhaust, and do not normally require cooling.
 - c. Extraction of this exhaust component heat in-flight with a proper downdraft cooling system is not a very large factor in cooling the cylinders, block, coolant, or oil. Proper downdraft cooling usually makes the muffler/manifold heat a non issue as radiated heat is drawn away from the engine. Ground operations are affected most as the radiated heat contributes to engine compartment heat buildup during taxi/ground operations or during slow speed flight. This normally doesn't cause an adverse pressure gradient, but the higher under cowl heat can cause fuel vapor lock, poor turbo performance, and other heat stress problems.

- II. Transmission of power by means of a common propeller of fixed or variable pitch suitable for use on the Europa Aircraft provides thrust and ground cooling air.
 - A. Propeller efficiency is assumed at 78% min to 87% maximum.
 - B. Air movement in the 2.5 feet diameter around the cowl is assumed at:
 - 1. Idle / taxi power 50 fps (about 30 MPH)
 - 2. Takeoff power (standing still) 120 fps (about 80 MPH)
 - 3. Flight speed is the assumed inlet speed for flight operations.
 - 4. No provisions are made for water spray or augmented vent fans for additional cooling.

- III. Engine Cowl shape
 - A. The XS cowl has inlets designed to provide ram air directly to the front cylinders.
 - B. Gills of 16 square inches are supplied on the upper side of the cowl for air exit on the top cowl.
 - C. The inlet for the radiators is provided with an area of approximately 32 square inches.
 - D. A lower duct with exit area of approximately 85 square inches provides for air exhaust for radiators and cowl exhaust air.

- IV. Cooling Techniques employed by the XS cowl.
 - A. Inlets. The inlets are nominally 3 inches in diameter equaling 14.2 square inches of inlet air for cylinder cooling (2 square inches less than recommended by Rotax which is an inlet of about 3.2 inches diameter).
 - B. Louvered Gills. The automotive style gills on the sides provide about 16 square inches of opening for cylinder cooling air exhaust.
 - C. Lower Duct. The ramp style cowl exit provides about 95 inches of area on an angle to the exit flow. On the mono wheel, firewall position and radiator duct aft end position provides for about 15 inches of exit air for cowl cooling exhaust. The area from the sides of the cowl duct to the radiator ducting provides an additional 15 square inches of exit air for the cowl cooling air exhaust. Radiator duct exhaust air exit is about 65 square inches. The ramp is angled approximately 23 degrees to the slipstream to provide a draw (negative pressure) to extract cowl air and assure a pressure drop across the coolers.
 - D. A recommended Rotax supplied cooling air baffle is recommended for cylinder cooling but not supplied by the kit manufacturer.
 - E. Cowl seal material is provided and sufficient for all lower duct sealing to the cowl.
 - F. There is no accommodation for returning exhausted cooling air to near flight speed.

- V. Ideal cowl principles commonly strived for, even by the XS cowl.
 - A. The ideal cowl would house the engine components with as little frontal area as possible, while keeping the front area near the prop as small as possible to reduce front pressure build up. The air that enters the cowl and radiators for cooling would be returned to the free airstream as near to aircraft speed or higher as possible.
 - B. Inlets are placed to maximize pressure and inflow possibilities, and exits made to extract inlet air and are secondary to reintroducing exhausted air as cleanly as possible to the slipstream over a large range of speeds.
 - C. Aerodynamic and mechanical devices to augment cooling such as ducting and cowl flaps would be minimized to simplify construction.

Note: When you look at kit or production aircraft with fixed (non augmented) cowl entrance and exits, large inlets and even larger exits are provided and some ducting is used. Typical exit areas to entrance areas of 4 to one are common. The XS cowl is about 3-1.

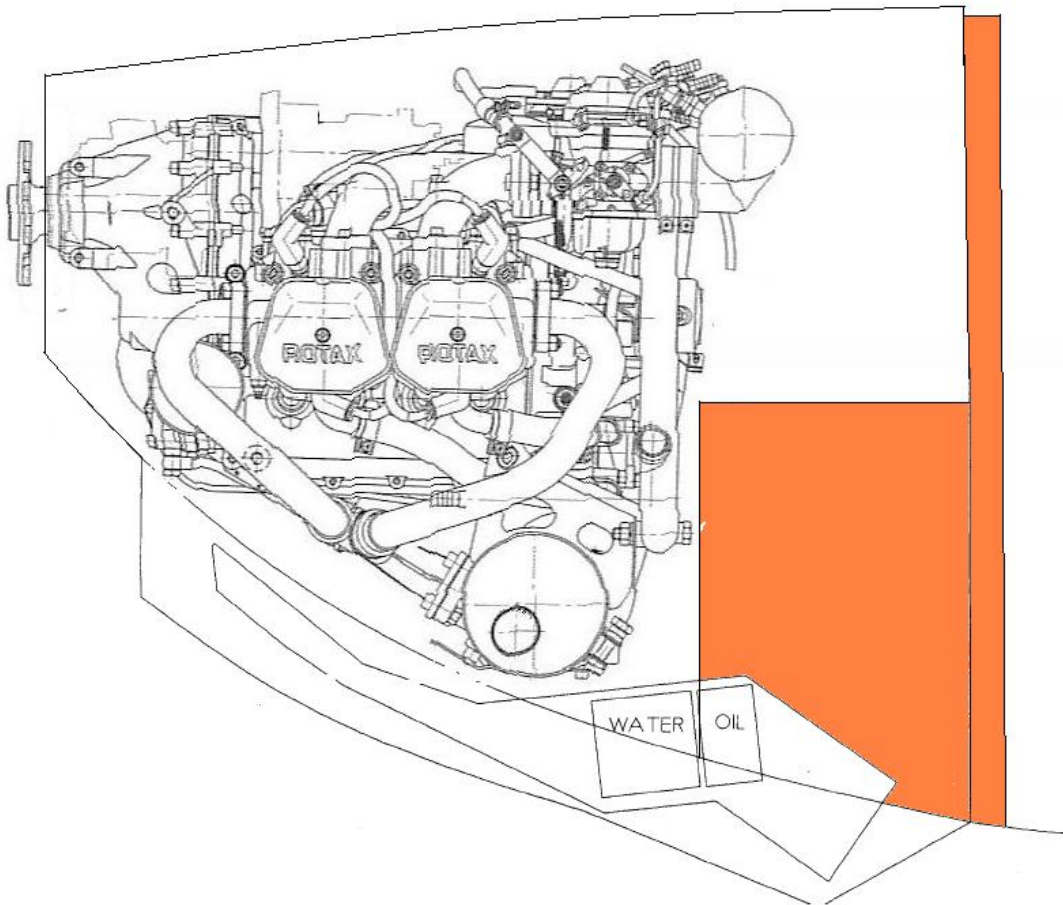

Part 3

Analysis of Europa Cooling

It is evident that the cooling of the Rotax 914 is unacceptable with ambient temperatures above standard day conditions. Full power operations normally cannot be conducted without overheating above 70F ambient temperature. Max angle of climb or even max rate of climb speeds do not provide for efficient cooling even at maximum continuous power settings. I have run my 914 on the ground without the cowl and it doesn't overheat at all. So this leads me to assume (ASS out of U and ME) the cowling has cooling efficiency problems.

The Europa Trigear aircraft seldom have the problems of cooling that the mono wheel has provided the trigear customer builds a firewall aft of the nose gear trapezes. The movement of the firewall of the trigear aft, some 16 inches, provides for 100 square inches of additional exit air from the cowl, aiding in the draft and providing sufficient airflow and better cooling during high power/low airspeed operations. Cruise power settings in the trigear rarely encounter overheating even when outside temperatures exceed 95F. Therefore most of the discussion below will apply

to the mono wheel and its peculiar problems. The techniques employed for mono wheel cooling would enhance trigear operations as well.

Cowl shape. The cowl shape is as close as is practical to the engine and allows for ease of assembly. Insufficient room is allowed for exhaust pipe clearance of the front (1 and 2 cylinder) and the bump in the bottom of the port side of the cowl for the muffler no longer clears for the newer 912S exhaust system. The cowl is made for an average sized spinner of 10 inches and accommodates most propellers of either fixed, ground adjustable or constant speed types.

Radiator size and placement.

1. The radiator provided by Europa, provides about 82 square inches of cooling plate area and 35 inches of face area, slightly above what the engine manufacturer recommends. The oil cooler is sized at 120 square inches of plate area with a face area of 40 square inches and should be suitable.

Current Europa XS cowl cooling analysis:

1. The inlets for ram air are positioned directly in front of cylinder 1 and 2. The area of the cooling air inlets is less than that recommended by the manufacturer and should be increased in size to at least 3.5 or 4 inches. No other inlets are intended for ram air cooling.
2. There are no provisions for air ducting, plenums or flow control in the cowl for cylinder cooling air (the finned area) either from an updraft or downdraft pressure method by the kit manufacturer. Without the Rotax supplied ducting and cowl mods, ram air impacts the front two cylinders and appears to move downward directly to the two triangle exit areas formed by the gap between the ramp exit and radiator duct exit. The exit area formed by the gills on the side is available, but it is my opinion that insufficient suction is formed by the gills to allow for cooling air exit. The path of least resistance for the cooling ram air is wasted by going out the sides of the duct in the rear bottom of the cowl. This leaves no cooling for #3 and 4 cylinders, carburetors or ignition/electrical components. A situation ripe for vapor lock.
3. A ram air NACA inlet and plenum is provided for turbo inlet use and a small cutout into the plenum duct and around the air filter pushes high pressure duct inlet air into the lower cowl forming an unacceptable pressure gradient in the lower cowl, reducing the ram air cooling further for the cylinders above. However, these cutouts may in fact provide cooling air for the turbo.
4. No provisions are made for turbo and exhaust component heat extraction. The ram air cutout and filter hole cutouts provide about 4 and 5 square inches of ram air cooling respectively to the turbo. No special ducting or heat shielding of the exhaust system is made.

Cooling flows of the 914 Mono

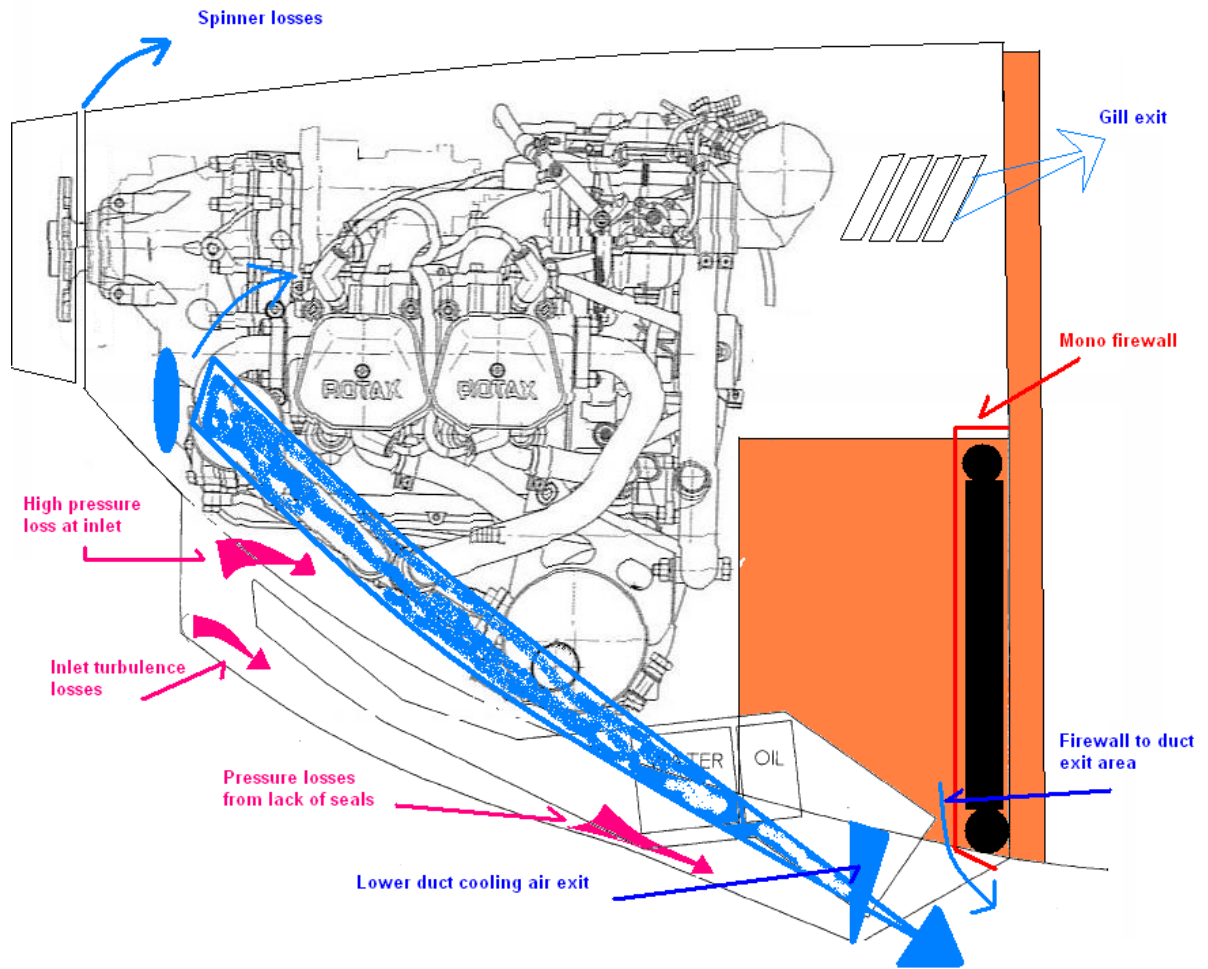

5. Radiator inlet to radiator size is sufficient. The radiator face is 35 inches and the oil cooler, when dropped 2 inches, provides an effective area of 40 inches. Together, due to some overlap, they are an exposed faces of about 60 square inches. The radiator inlet duct of the Europa is 32 square inches making for an expansion of the air, although not smoothly, of about 2 to one. Over the inlet length of 12 inches (inlet to radiator face) this leaves us with about a 15 degree expansion slope (not exactly isentropic flow but close enough). This would allow for cooling air to slow, expand, and allow for better heat transfer rate going through the coolers.

6. The exit air from the radiators is approximately 65 square inches allowing for potentially an acceptable pressure gradient for cooling air flow. However, the duct makes an abrupt change in direction and builds pressure in making this corner above and behind the oil cooler. The angle of the duct to the slipstream provides for some suction draw as a cowl flap would. There is no provision for re-entry of the air to near slip stream velocity.

Customer applied fixes for cooling.

The Europa engine installation manual and kit provides for a duct beneath the starboard inlet for a Rotax supplied air inlet and cooling shroud for use over the cylinders. Many touted this shroud as too expensive, difficult to install and unnecessary. For the trigear, this is generally true. In some instances where other modifications have caused the planes to overheat, owners have installed this cooling shroud or made their own and have had moderate success.

I have modified the cowl with success by moving the inlets up to even with the spinner horizontal axis and enlarged them to nearly 4 inches. The higher inlet nozzles bring air in just above the front cylinders and with very little effort easily applied ducting can provide excellent down draft cooling. One customer preferred not to use the ducting and his trigear cooling is acceptable except at high outside temperatures (90F) on low speed climb outs below 90 KIAS. This inlet nozzle position works because the cooling air hits the carburetor, expansion tank and ignition area, creating a high pressure area aiding in cooling provided higher climb speeds are maintained. Very tight duct sealing in the lower cowl of his plane allows for some upper engine cooling and down draft, and the system works for him. Moving the cowl inlets have a side benefit in that a belt driven alternator can be added with little cowl modification. (Airmaster Propeller provides a through the shaft brush setup for just this alternator setup and it works for the Whirlwind Propeller as well.)



Others have lowered the radiator inlet duct making a P-51 style inlet to improve the smoothness of the inlet flow and others have smoothed the radiator duct exit to provide a smoother exit. These mods have had some success. The trigear leg gets in the way of ducting a smooth entry of the air back into the slipstream and makes cowl installation tricky, but the same can be done for the trigear also.

One mono has a cowl flap which extends down from just below the oil cooler and also lowers the upper metal duct which improved low speed climb out and ground operating times. He went from 10 minutes until overheat on the ground to 25. During the climb, the cowl flap again improved cylinder head cooling temperatures and radiator efficiency.

Another idea was to put cowl flap style reverse ramps (like a cowl flap) in place of the gills to promote more exit air potential for the upper cowl. This may be particularly effective if an intercooler is installed on the Rotax 914.

Another technique to improve exit air draw is to widen the duct ramp about 4 more inches (see left drawing below). This mod allows for more exit area on the sides of the radiator duct and provides for a highly efficient draft in the lower cowl, but without ducting to force inlet air into a plenum above the engine, the air from a normally placed inlet will make a bee line to the exit area, completely bypassing the upper engine cylinder cooling needs. Inlet ducting is needed to force a down draft over the engine cylinders for optimum performance of this mod.

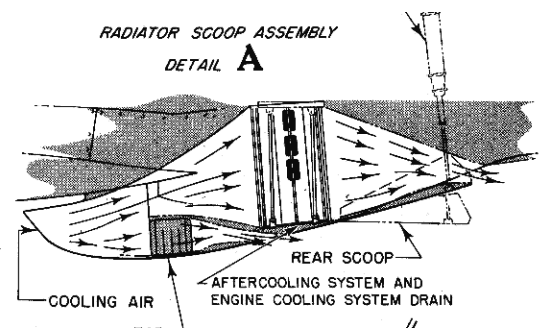
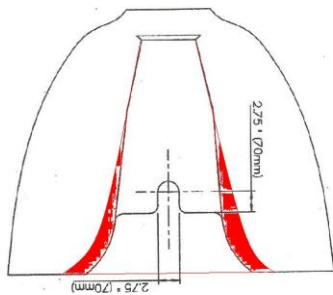

Many have commented that the technology used by the P-51 and other fighter aircraft were very efficient at reducing the cooling losses in flight. However, many overlook the fact that the highly efficient radiator cooling systems were intended for short ground run times, and required extensive ducting work and large amounts of internal aircraft area for the ducting (See drawing at right above). These highly efficient radiator coolers however still needed cowl flaps to provide minimum suitable ground operating times before overheating. Even at maneuvering speed, cowl flap deployment was necessary in tropical environments at low altitudes and high power settings to provide sufficient cooling. Many of these now private warbirds incorporate water sprays to make extended ground operations and high power operations possible even at the lower boost (power) and fuel octane required for operations today.

Part 4

Some workable solutions

Since I am based in Florida and operate in tropical flying operations I feel the existing cowl should be modified to create acceptable performance in hotter than standard conditions. I will outline my modification ideas for the existing cowl first, then some all new cowl ideas.

For the Existing cowl, here are a dozen workable solutions for the mono and tri-gear

1. Cut, extend or build out the cowl in areas where exhaust components conflict with the cowl and allow for at least ½ inch of clearance from the cowl inside surface and the exhaust system components. This is essential as Rotax and the muffler manufacturer have changed their exhaust pipe and muffler dimensions over the years. (See examples below.)



2. Direct air over the engine down through the cylinders. Build a plenum above the engine to trap the inlet air above the cylinders and create a down draft system. If you build a plenum, try to keep it tight to the cowl and engine for best efficiency. (One example is shown below.) The Rotax plenum P/N 975795 works and can be modified easily to fit the existing cowl by adding additional air intakes as the Europa firewall forward for the Rotax installation manual shows. Extending the plenum to cool the carbs may help also.

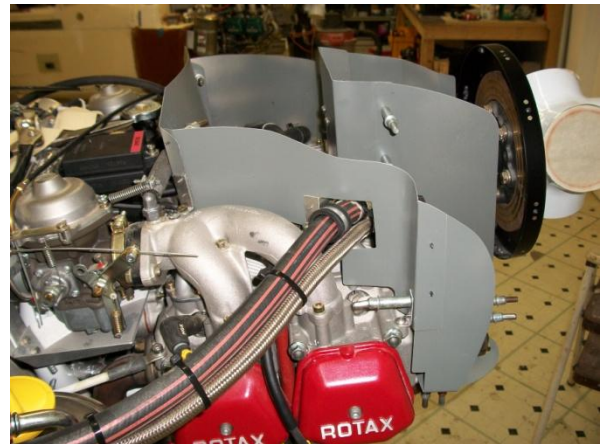

Cowl seals are uninstalled in these photos.

3. Close up the gills, unless you need them to vent high pressure air from your intercooler or other devices. Intercooler ducting should be tight and the inlet and exit air well planned. Venting the intercooler into the cowl will work, but may need additional exit area or ducting to draw out his high pressure air. Gills work as a pressure exit better than a device to pull the heated air from the cowl. Their position allows air for cooling the cylinders out of the top of the cowl rather than drawing the heated air out past the exhaust components then out of the cowl lower duct. They also draw air away from the number 3 and 4 cylinders and may promote more heat stress and stagnant hot air around the carburetors.
4. Move the mono wheel metal firewall aft to the bungees. It can be done, requires engine removal only to prevent cuts and cursing, but gives one more inch clearance for cooling air behind the radiator duct. This will allow more efficient draft of the hot cowl air.
5. Make your radiator ducting fit well and your cowl seal around the entire duct, including the front as air tight as possible. This promotes an acceptable pressure gradient across the radiators for optimum cooling. The duct seals also prevent high pressure duct air prior to the radiators from leaking into the lower cowl making for a decreased pressure gradient for cylinder cooling.
6. Drop your oil cooler as far down as your cowl will allow. Two inches is about right. Seal the gaps on the sides between the radiators and sides of the metal duct. I build a metal seal for the sides of the oil cooler and construct a metal or fiber seal between the oil cooler and bottom of the cowl. (See below)



7. Open the area on the aft of the radiator duct up by either removing material or re-bending the exit to allow for more exit area for cowl air and a smoother transition on exit for the radiator exit air.



8. If you have to cut the cowl to clear exhaust pipes and or muffler, why not extend the sides of the duct out a bit to widen it. This requires much more time and modifications to the cowl. The standard metal duct sides may need to be extended to allow for proper sealing between the duct and sides.

(Photo at right above shows the cowl with the extension over an existing cowl.)

9. Use special exhaust wrap tape to cut exhaust heat from the pipes. Put heat reflective tape or sleeves for the cooling and fuel hoses. The racing community swears by the exhaust heat wrap, but I haven't tried it.

10. Enlarge your round inlet holes a bit. Typically it is easy to open them up to about 3.2 inches. Make sure there is a smooth inlet into the cowl. Some owners have forgotten to clean up the intakes and leave flashing from the cowl molding to restrict air and add turbulent flow. A smoothly rolled entrance to the two round ducts is more efficient than a sharp transition.

11. Keep your spinner to cowl distance about 3/16 of an inch or so. 1/8 is my personal minimum. A small gap here keeps air from rushing out of the top of the cowl.



12. Add foam to the radiator duct inlet and a layer of glass to smooth the cowl entry. Also make sure the top of the inlet seals to the front of the duct. (See photo above)

Part 5 New Cowl Ideas

OK, let's get practical or let's get radical.

For the Mono, practical is to just do all or some of the dozen items in Part 4 above. What does the outside of the cowl look like? Well, just about the same, but with the differences in the picture below.

Easy fix for 914 Mono

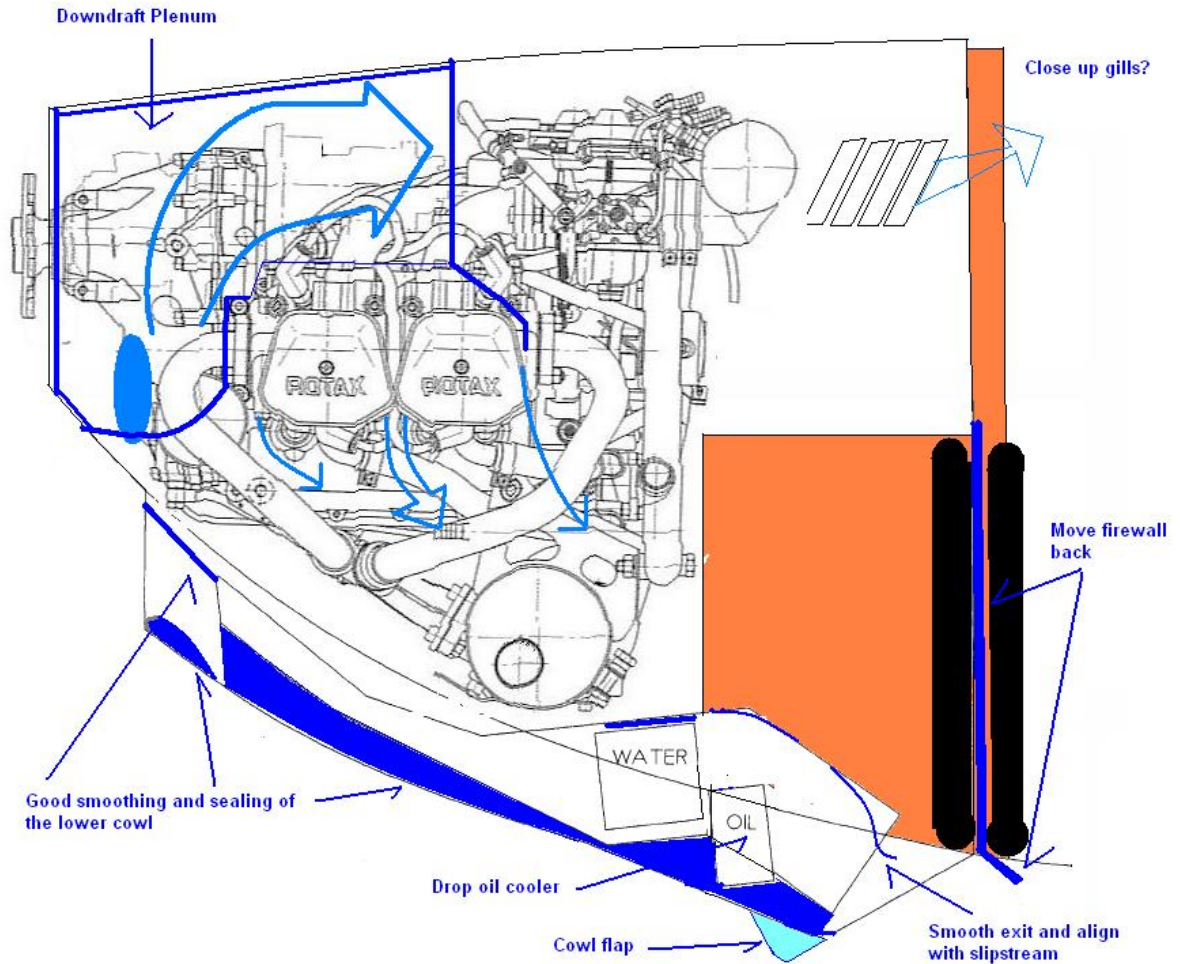

Add a plenum, smooth some air flow in the duct, add a cowl flap if you need to and move your firewall aft a bit or make the exit duct shorter to widen the firewall to duct gap. The plenum pictures in Part 4 that I have made are tedious and time consuming without proper tools, but are easy with a good pair of snips and a file folder paper pattern. Tight downdraft plenum ducting will aid in the evacuation of the heat of the exhaust as well as the engine cylinders by creating positive pressure over the top of the engine then combined with the draw of the exit duct negative pressure, cooling will be improved. Looking from the outside of the aircraft at the cowl mods above, to the casual observer, most see nothing different, including the wider cowl exit. Pay attention if you leave the gills open. They may draw upper pressurized air out leaving less for lower engine/exhaust cooling. Test your gills and see if there is a difference.

What is practical for the tri gear. It's pretty easy really. You may push your duct all the way back to the gear mounting frame if you like. No cowl flap is necessary, but because the duct of the cowl is so far forward of the tri gear exit hole, and the radiator exit air is forced into the slipstream at an angle, there is still not a lot of draw for the cowl hot air out of the hole. A plenum is still a good safe bet for summertime cooling at low speeds and high power settings.

Easy fix for the Tri Gear

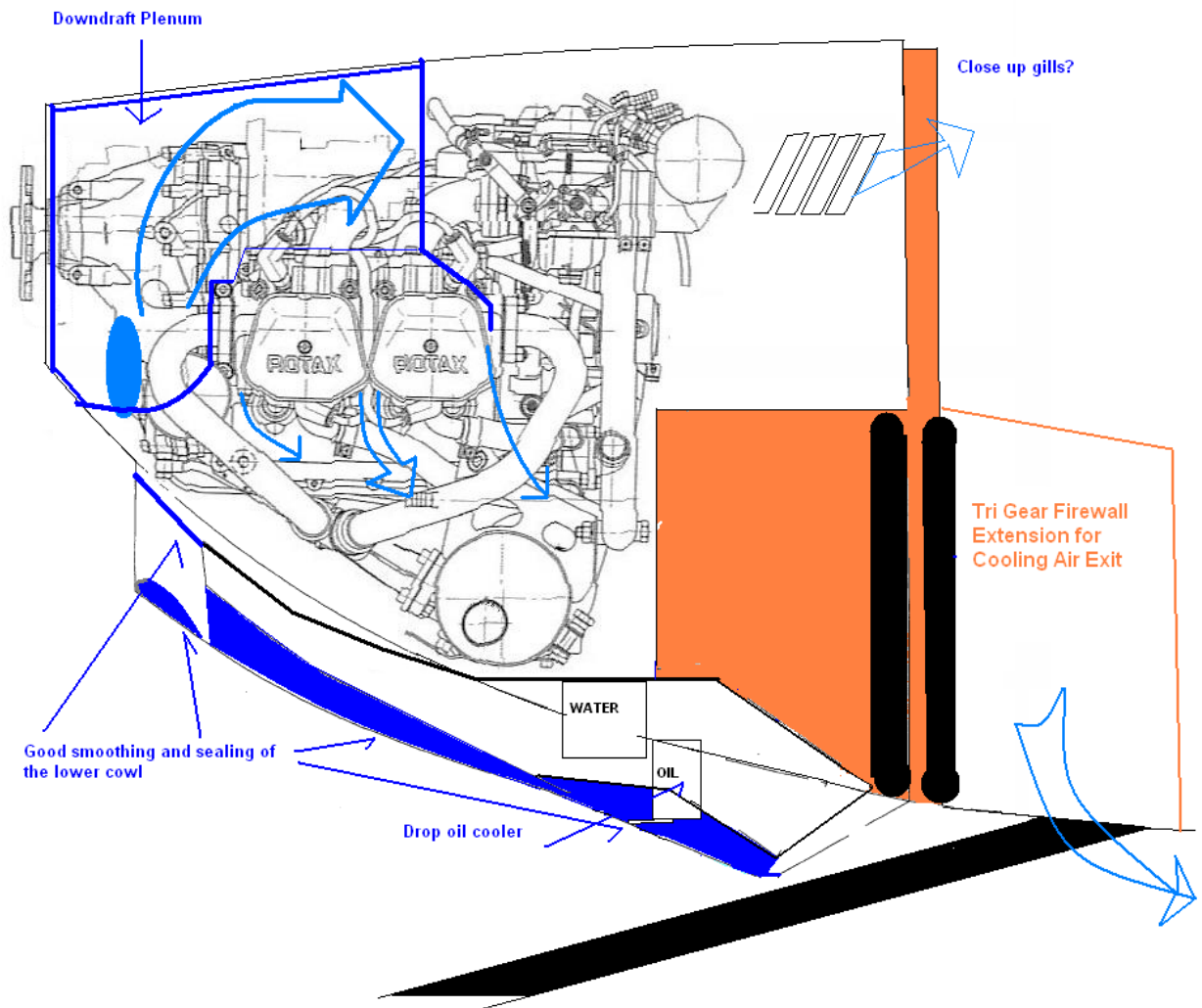

If you move your inlets up to even with the horizontal axis of the spinner, you have more options. Looking at Jerry Hope's tri gear aircraft below, the inlets are clearly moved up. A plenum for his plane would be a breeze as fewer pieces are required due to the larger, higher intakes, and his alternator from Rotax still fits OK in the port hole. Otherwise, pretty much simple fixes that require a number of hours of shaping, glassing and filling. Jerry's inlets are larger, the exhaust clearance better all around and the air exit is plenty since it is a trigear. (See Jerry Hope's modifications below.)



What about Europa Aircraft. Why are they not responding to our obvious concerns.

Well they are. Dave Stanbridge has taken the ideas above and has put the cowl data into a laser scanned CAD program where engineering analysis and visualization are easier to see. This makes a 3D rendition of the internal equipment and ducting shapes easy to see and evaluate. Optimization of the cowl shape is easy as point and click and the CAD interface can be hooked to a CNC machine to build a plug from foam. But, as any engineer knows, this process is very expensive and time consuming to do well. Finally, it is still tough to do flow analysis in any cowl without physically building it and flying it. (See examples of Cowl ideas below.)

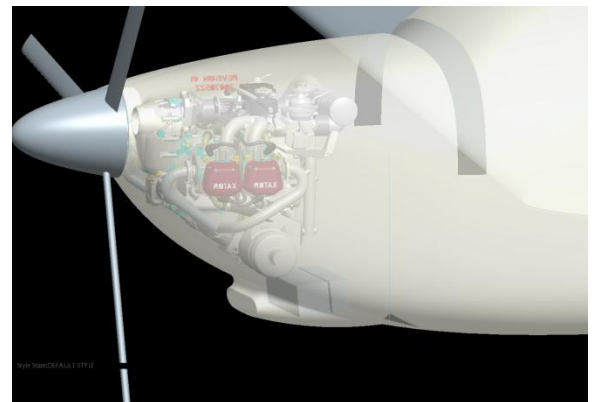
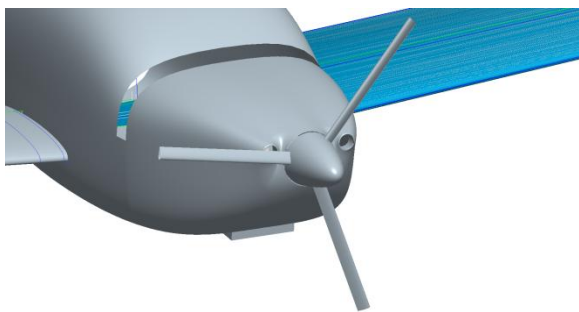

How about getting radical!

What about moving things around. From my studies of WWII aircraft cooling radiators I thought of an idea of moving the coolers forward of the foot wells and adding an exhaust augments cowl scavenge device. Moving the coolers down in front of the foot wells allows for easy access to the coolers, and opens up the center tunnel for hot cowl air exhaust between the radiators. Of course cowl flaps will allow the pilot to adjust pressure ratios across the radiators for better cooling at low speeds and potentially less drag at cruise.

However, the intakes for these two coolers is quite far from the prop blast which makes ground operations potentially a problem as a delta P across the radiators would be tough to maintain during ground operations. Perhaps we could put a drooped inlet to allow more ram inlet airflow to improve the pressure at the face of the radiators which works along with the cowl flap extension.

Also why we are at it, why not plan in an intercooler setup for normal cowl installation. Swap the oil cooler to the port side and put in a large, horizontal intercooler for better hot weather performance. If we add pressurized water spray for all the coolers, we could radically cool our engines at high power settings. I figure about 500 man hours and it could be put onto a plane to test. Who knows, with good exit design, we may even get more speed from the thrust of the exhaust augments, water mass flow and aerodynamic pressure recovery systems of the coolers. (See some of the “every gimmick I know” ideas in the drawing below.)

Out there cowl ideas

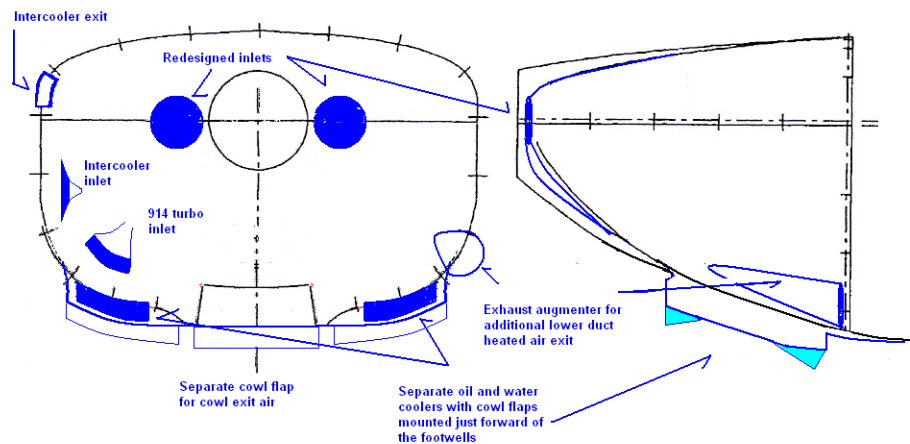

In Summary:

The cooling issues of the existing Europa XS cowl are not hard to overcome. To kit builders, the current cowl is disappointing in that the cooling/clearance corrections and or improvements are not factory standard. Not all of us can visualize how air moves in the cowl and anticipate all the needs of our engine cooling. Most kit builders would prefer the recommended Rotax installation

be just plug and play. Europa is just like the other manufacturers where we allow you to make your own custom cooling decisions based on your flying, region, engine type, prop type etc. But let's face it; the XS cowl is fine for a 912, 80 hp engine during a hot US summer day. This engine rarely has cooling issues in moderate temps when using this cowl. Unfortunately most of us tend to believe more is better when it comes to horse power, and cram a 914 or 912S into the lightweight mono wheel steeds and are faced with the fact we must now modify to get acceptable cooling performance in the hot US summers verses the cooler European climate.

The discussed modifications in 4 above are the types of modifications that I do at Custom Flight and have never shared before except with my customers, because they pay for the service. Each of my cowl mods are completed after lengthy talks with the client and analysis of their needs. For me, making bumps and extensions to a cowl is second nature, but for a kit manufacturer, production changes are made when a compilation of data and field reports are compiled into an operational requirement. After that, modifications can be made and tested, and manpower and money is thrown at the fix. When fully proven, then production molds are made and manuals written. My fixes are one off, and satisfy my customers who have had a hands on input in making these mod decisions or not. You too can make one offs and satisfy your cooling issues and concerns. As I tell my clients, let's whack it, after all, it's just fiberglass!

References:

Some references obtainable on the web you too may want to look into in designing your own mods or just gathering information. The articles and reports below are applicable in any light aircraft cooling considerations:

Journals:

Aircraft Engineering and Aerospace Technology Vol 8 Issue 8

AIAA80-1242R Cooling Air Inlet and Exit Geometries on Aircraft Engine Installations
Journal of Aircraft Volume19, Number7, July 1982, Page525.
J. Katz, V.R. Corsiglia, P.R. Barlow

Other Aircraft manufacturer and builder articles:

Design for optimum cooling efficiency; Longeze news letter

Building Basics / Cooling Drag by Christopher Zavatson, EAA 445507; from EAA Sport Aviation Magazine Dec 2007

AircraftEfficiencyRV4Improvements; found on line in .pdf file presumably from the VAF forums

Aircraft Cooling Systems by Pete Law. Primarily for the racing enthusiast

NACA Reports:

CR 3405 Cooling of horizontally opposed aircraft engines
3H16 Wartime Report on improved baffle designs
TN 620 Energy loss and temp dist for a baffeled cylinder model
TR1038 Inlet and outlet design testing

Manufacturer studies:

LCHX Performance curves (for oil coolers) ; by Stewart Warner